

Exinda Virtualization Deployment Guide

Exinda ExOS Version 6.3

© 2012 Exinda Inc.

Table of Contents

Part I Introduction	6
1 Using this Guide	6
2 Further Reading	7
Part II Overview	10
Part III Where to find the Exinda virtual appliance software	12
Part IV Sizing Guidance	14
1 What are IOPS	14
2 2750	16
3 4750	16
4 6750	17
5 8750	18
6 2850	18
7 4850	19
8 6850	20
Part V Use Cases	22
1 How VMotion Works	22
2 Use Case 1: In-line deployment with externally attached LAN	23
Use Case 1: Expanded View of VMware ESXi	25
3 Use Case 2: In-line deployment with an isolated virtual LAN and virtual applications	26
Use Case 2: Expanded View of VMware ESXi	27
4 Use Case 3: Out-of band (WCCP) mode	28
Use Case 3: Expanded View of VMware ESXi	30
5 Use Case 4: Port Mirroring / SPAN Port Configuration	31
Use Case 4: Expanded View of VMware ESXi with external Nexus switch	32
Use Case 4: Expanded View of VMware ESXi with a virtual Nexus switch	33
6 Use Case 5: Virtual WAN Simulator in Isolated Network	34
Use Case 5: Expanded View of VMware ESXi & WAN simulator	35
7 Use Case 6: VMware High Availability	37
8 Use Case 7: VMware Fault Tolerant Cluster	38
9 Hypervisor Limitations	40

Part

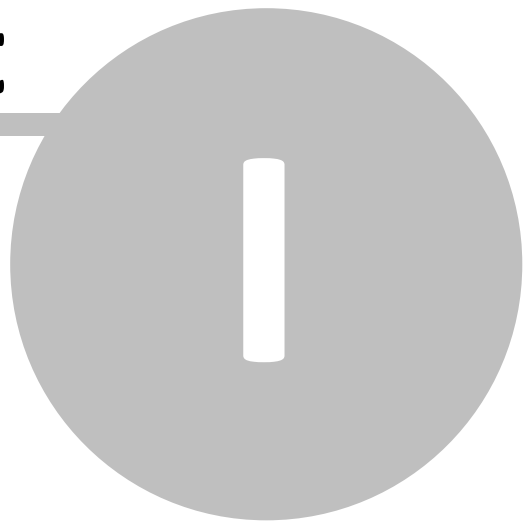

1 Introduction

Exinda Virtualization Deployment Guide

Exinda Firmware Version: 6.3

All rights reserved. No parts of this work may be reproduced in any form or by any means - graphic, electronic, or mechanical, including photocopying, recording, taping, or information storage and retrieval systems - without the written permission of the publisher.

Products that are referred to in this document may be either trademarks and/or registered trademarks of the respective owners. The publisher and the author make no claim to these trademarks.

While every precaution has been taken in the preparation of this document, the publisher and the author assume no responsibility for errors or omissions, or for damages resulting from the use of information contained in this document or from the use of programs and source code that may accompany it. In no event shall the publisher and the author be liable for any loss of profit or any other commercial damage caused or alleged to have been caused directly or indirectly by this document.

1.1 Using this Guide

Throughout the manual the following text styles are used to highlight important points:

- Useful features, hints and important issues are called "notes" and they are identified in a light blue background.

Note: This is a note.

- Practical examples are presented throughout the manual for deeper understanding of specific concepts. These are called "examples" and are identified with a light green background.

This is an example.

- Warnings that can cause damage to the device are included when necessary. These are indicated by the word "caution" and are highlighted in yellow.

Caution: This is a caution.

1.2 Further Reading

In addition to this guide, the following additional user documentation is available:

- Exinda Quick Start Guides
- Exinda User Manual
- Exinda Command Line Interface (CLI) Reference Guide
- Exinda "How To" Guides
- Exinda Licensing Guides

Please visit <http://www.exinda.com> for more information.

Part

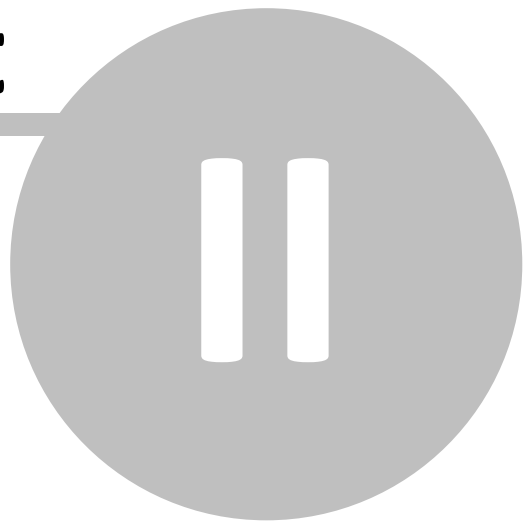

2 Overview

Exinda supports a virtualization solution for most of the well-known hypervisor solutions, including:

- VMware ESX/ESXi versions 4.0, 4.1, and 5.0
- Microsoft Hyper-V Windows 2008
- Citrix XenServer versions 5.5, 5.6, and 6.0
- KVM

This document provides an overview of the supported Exinda deployments for its virtualization solution, and includes the following information:

- Diagrams of each supported deployment,
- Lists of supported software versions,
- Recommendations for sizing (CPU, Memory, and storage),
- Limitations for each hypervisors, where applicable,
- Reference links for supporting material.

Part

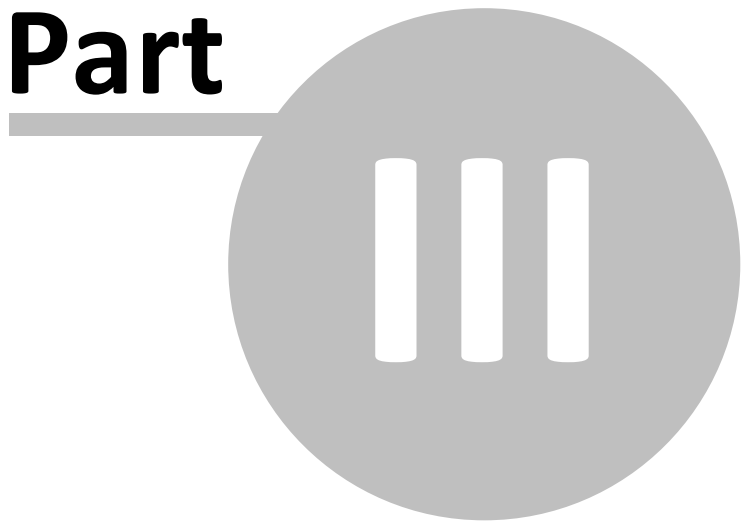

3 Where to find the Exinda virtual appliance software

- [Download the Exinda virtual appliance.](#)
- License the virtual appliance after you have downloaded the software. Step-by-step instructions to license the Exinda virtual appliance as a trial, or for purchase are available in the [Exinda Virtualized Appliance Licensing Guide](#).
- Reference the [How to Guide for installing the Exinda virtual appliance](#).

Warning: After the license has been installed on the virtual machine, you **MUST** check for updates to the Exinda software. To check for the latest update, in the Exinda Web UI go to **System > Maintenance > Firmware Update** and click **Check for Latest Update**. Install any updates available for the Exinda.

Part

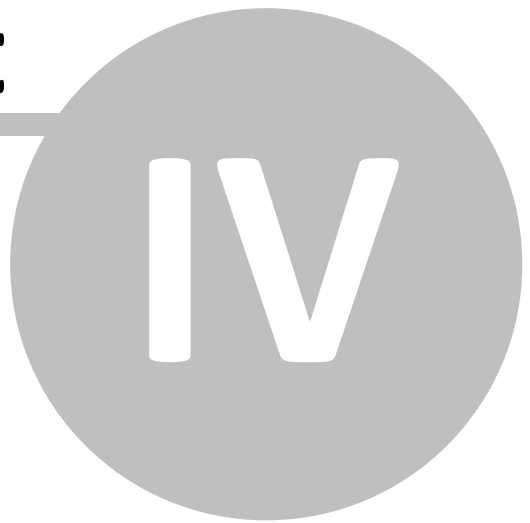

4 Sizing Guidance

To see the recommended (and minimum where noted) hardware configuration requirements for CPU, memory, and disk storage for the available models, and determine which is right for your deployment, refer to the charts below or to the Sizing Guide available in the [Exinda Virtual Appliance product sheet](#).

Exinda supports the following products and scalability:

- X700 Series – 2Mbps to 500Mbps for Traffic Shaping and Visibility
- X800 Series – 1Mbps to 45Mbps for WAN Optimization, Traffic Shaping and Visibility

Note: The recommended CPU is the minimum CPU(s) to achieve the performance numbers. The CPU must be VT Enabled & 64-bit.

The Exinda virtual appliance has a Flexible Storage option, with which you can adjust the size of the storage for Edge Cache, CIFS cache and WAN Memory. By increasing the virtual file sizes for each of the three caches mentioned, you can greatly improve the performance of your Exinda virtual appliance.

For Edge Cache and CIFS Cache there is no limit on the size of the file created in the external storage. Use common sense when creating the file sizes. Exinda recommends 80% of the actual file size be allocated to Edge Cache and CIFS Cache. For example, if your CIFS cache is 1TB then the recommendation is 800MB.

For WAN Memory, size based on the following:

- For systems with 2GB RAM – Max WAN Memory Cache is 300GB
- For all other systems – Max WAN Memory Cache is 1TB

4.1 What are IOPS

IOPS (Input/output Operations per Second; pronounced eye-ops) is a common performance measurement used to benchmark computer storage devices like hard disk drives (HDD), solid state drives (SSD), and storage area networks (SAN). As with any benchmark, IOPS numbers published by storage device manufacturers do not guarantee real-world application performance. IOPS are measured in both Commands per Second (IO operations per second) or Throughput (Megabytes per Second).

In the sizing charts for the Exinda virtual appliance (EX-V) we have represented the measurement in Commands per Second. There are three numbers for IOPS:

- EC IOPS for Edge Cache IOPS
- Monitoring IOPS

- Average IOPS for Optimization IOPS

To calculate the IOPS for EX-V you will add the IOPS for each service:

Edge Cache IOPS + Monitoring IOPS + Average Optimization IOPS = Total IOPS

Example: Model - 2850-6	IOPS
Edge Cache IOPS	30
Monitoring IOPS	140
Average Optimization IOPS	200
Total IOPS	370

To monitor the IOPS in VMware vSphere:

1. On the Custom Performance Chart for the EX-V, select the **Virtual disk > Real-time** chart option.
2. Select **Average write requests per second (inbound and outbound)**.

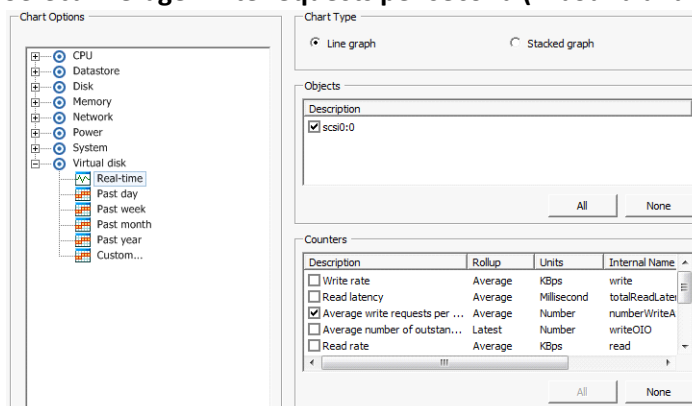

The report indicates the Minimum, Maximum, and Average Commands per Second.



4.2 2750

Exinda Model	2750		
Licensed Bandwidth (Full Duplex)	2	10	20
Max Concurrent Flows (K)	32K	32K	32K
Max L7 New Connection Rate	30	30	30
Reports	4	4	4
SLAs	10	10	20
APS Objects	20	20	20
Policies	64	128	128
Edge Cache Max Throughput (Mbps)	4	4	4
Edge Cache Requests per Second	100	100	100
CPU(s)*	1 x 2Ghz	2 x 2Ghz	2 x 2Ghz
Minimum Storage (GB)	160	160	160
Minimum Memory (GB)	2	2	4
EC-IOPS	30	30	30
Monitoring-IOPS	140	140	140

4.3 4750

Exinda Model	4750							
Licensed Bandwidth (Full Duplex)	2	10	15	20	45	100	155	250
Max Concurrent Flows (K)	64K	128K	128K	256K	256K	384K	512K	768K
Max L7 New Connection Rate	300	300	300	300	300	300	300	300
Reports	4	6	8	10	16	20	20	20
SLAs	70	100	100	120	120	150	150	150

APS Objects	150	150	150	150	150	150	150	150
Policies	128	256	256	384	384	512	512	512
Edge Cache Max Throughput (Mbps)	20	20	20	20	20	20	20	20
Edge Cache Requests per Second	1500	1500	1500	1500	1500	1500	1500	1500
CPU(s)*	2 x 2Ghz	2 x 2Ghz	2 x 2Ghz	2 x 2Ghz	2 x 2.4Ghz	2 x 2.4Ghz	4 x 2.4Ghz	4 x 2.4Ghz
Minimum Storage (GB)	250	250	250-500	250-500	500	500	500-1000	500-1000
Minimum Memory (GB)	2	4	4	6	6	6	8	8
EC-IOPS	50	50	50	50	50	50	50	50
Monitoring-IOPS	140	140	140	140	150	150	150	150

4.4 6750

Exinda Model	6750			
Licensed Bandwidth (Full Duplex)	45	100	250	500
Max Concurrent Flows (K)	512K	512K	768K	1024K
Max L7 New Connection Rate	1K	1K	1K	1K
Reports	20	20	40	60
SLAs	100	100	250	250
APS Objects	200	200	200	200
Policies	1024	1024	1536	2048
Edge Cache Max Throughput (Mbps)	125	125	125	125
Edge Cache Requests per Second	2K	2K	2K	2K
CPU(s)*	2 x 2.4Ghz	2 x 2.4Ghz	4 x 2.4Ghz	4 x 2.4Ghz
Minimum Storage (GB)	500	500	500-1000	500-1000
Minimum Memory (GB)	4	6	8	10
EC-IOPS	70	70	70	70
Monitoring-IOPS	150	150	150	150

4.5 8750

Exinda Model	8750		
Licensed Bandwidth (Full Duplex)	100	250	500
Max Concurrent Flows (K)	2048K	2048K	2048K
Max L7 New Connection Rate	6K	6K	6K
Reports	80	80	80
SLAs	250	250	250
APS Objects	250	250	250
Policies	2048	2048	2048
Edge Cache Max Throughput (Mbps)	175	175	175
Edge Cache Requests per Second	2.5K	2.5K	2.5K
CPU(s)*	1 x 2Ghz	2 x 2Ghz	2 x 2Ghz
Minimum Storage (GB)	1500	1500	1500
Minimum Memory (GB)	6	8	10
EC-IOPS	80	80	80
Monitoring-IOPS	150	150	150

4.6 2850

Exinda Model	2850		
Licensed Bandwidth (Full Duplex)	1	2	6
Max Concurrent Flows (K)	32K	32K	32K
Max L7 New Connection Rate	30	30	30
Reports	4	4	4

SLAs	10	10	20
APS Objects	20	20	20
Policies	64	128	128
Edge Cache Max Throughput (Mbps)	4	4	4
Edge Cache Requests per Second	100	100	100
Optimized Connections	100	150	250
CPU(s)*	1 x 2Ghz	1 x 2Ghz	2 x 2Ghz
Minimum Storage (GB)	160	160	160
Minimum Memory (GB)	2	2	4
Average - IOPS	80	90	200

4.7 4850

Exinda Model	4850					
	1	2	3	6	10	20
Licensed Bandwidth (Full Duplex)	1	2	3	6	10	20
Max Concurrent Flows (K)	32K	64K	64K	128K	256K	384K
Max L7 New Connection Rate	300	300	300	300	300	300
Reports	4	6	6	8	10	12
SLAs	40	60	60	80	100	120
APS Objects	150	150	150	150	150	150
Policies	128	128	128	256	256	384
Edge Cache Max Throughput (Mbps)	20	20	20	20	20	20
Edge Cache Requests per Second	1500	1500	1500	1500	1500	1500
Optimized Connections	1000	1500	1800	2000	2500	3000
CPU(s)*	2 x 2Ghz	2 x 2Ghz	2 x 2Ghz	2 x 2Ghz	2 x 2Ghz	2 x 2Ghz
Minimum Storage (GB)	250	250	250	250	250-500	250-500
Minimum Memory (GB)	2	2	2	2	4	6

Average - IOPS	80	90	120	200	220	450
----------------	----	----	-----	-----	-----	-----

4.8 6850

Exinda Model	6850		
Licensed Bandwidth (Full Duplex)	10	20	45
Max Concurrent Flows (K)	256K	384K	384K
Max L7 New Connection Rate	1K	1K	1K
Reports	20	30	40
SLAs	100	100	250
APS Objects	200	200	200
Policies	1045	1536	1536
Edge Cache Max Throughput (Mbps)	125	125	125
Edge Cache Requests per Second	2K	2K	2K
Optimized Connections	5K	6K	7K
CPU(s)*	2 x 2.4Ghz	2 x 2.4Ghz	2 x 2.4Ghz
Minimum Storage (GB)	500	500	500
Minimum Memory (GB)	4	6	6
Average - IOPS	220	400	450

Part

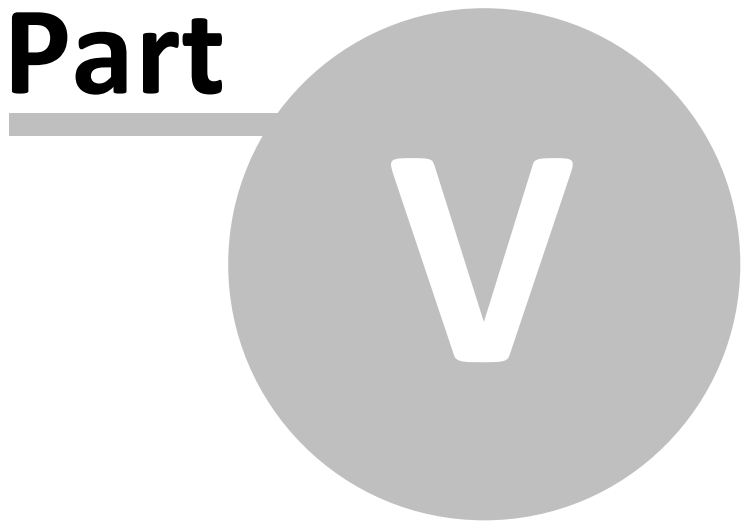

5 Use Cases

This guide contains a number of scenarios for deploying the Exinda virtual appliance (EX-V).

- [Use Case 1: In-line deployment with externally attached LAN](#)
- [Use Case 2: In-line deployment with an isolated virtual LAN and virtual applications](#)
- [Use Case 3: Out-of band \(WCCP\) mode](#)
- [Use Case 4: Port Mirroring / SPAN Port Configuration](#)
- [Use Case 5: Virtual WAN Simulator in Isolated Network](#)
- [Use Case 6: VMware High Availability](#)
- [Use Case 7: VMware Fault Tolerant Cluster](#)

5.1 How VMotion Works

For isolated virtual applications on the EX-V LAN port for inline mode, the VMware vMotion feature will not work. It is a requirement from VMware that any virtual switch must be mapped to a physical NIC, to an external network. Below is a brief illustration of the process.

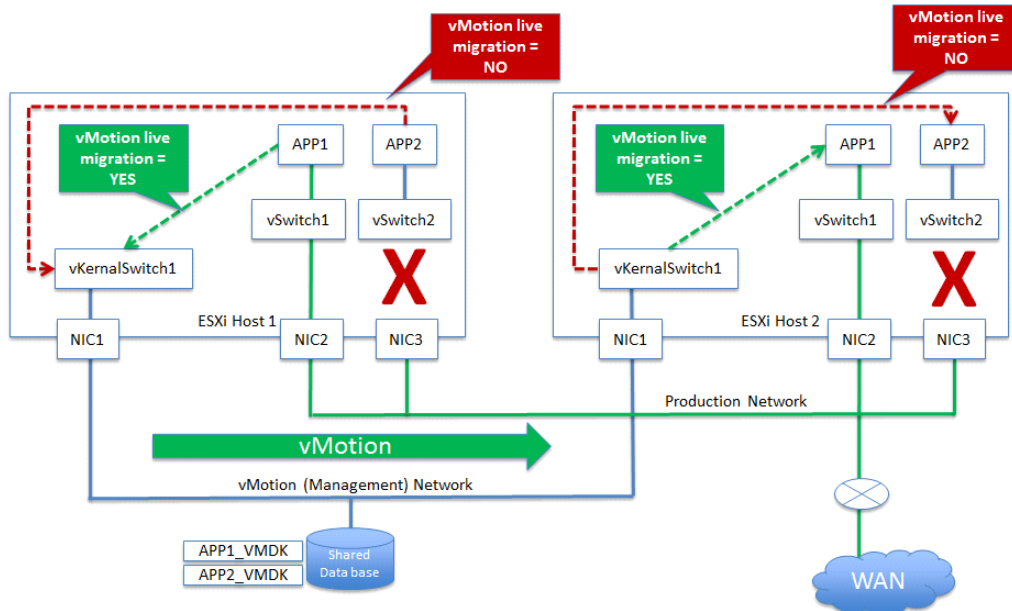

vMotion illustration:

- There are two types of virtual switches in the ESX/ESXi hypervisor: vKernel Switch and vSwitch. The vKernel Switch is used by the hypervisor exclusively. vKernel is the bare metal hypervisor, and provides core and memory allocation, disk and network virtualization, and driver to low level devices. The vSwitch is used by virtual machines, and behaves just like any external layer 2 switch. All virtual machines have a path to the external Data-store where each VMDK is stored through the hypervisor layer to the vKernel Switch mapped to the NIC attached to the storage.
- There are two networks:
 1. Management network where vMotion moves workloads between ESXi hosts, and
 2. Production network where the applications are accessed by the users.
- The vKernelSwitch1 is mapped to external NIC1 and connected to the management network.
- The vSwitch1 is mapped to NIC2 and connects APP1 to the production network.
- The vSwitch2 is mapped to APP2 and it does not have a mapping to external NIC3. The use case for this is that a network administrator may have one, or many, virtual workloads isolated on the host for testing purposes.
- vMotion is executed for APP1 on ESXi 1 and moved over to ESXi 2 with no disruption to the application workload.
- vMotion is executed for APP2 on ESXi 1 and fails because vSwitch2 mapped to APP2 is not mapped to an external NIC.
- If an EX-V has at least one vSwitch mapped to it, and the vSwitch is not mapped to an external NIC interface, vMotion will not work for EX-V or workloads isolated behind it.

5.2 Use Case 1: In-line deployment with externally attached LAN

In this use case, the EX-V is set up for In-Line mode deployment with an externally attached LAN. There are primarily two scenarios for in-line deployment of the virtual appliance:

1. The LAN-side users and applications connect to the EX-V through a physical NIC interface.
2. The applications are virtualized and isolated on the same host as the Exinda, on the LAN side interface of the EX-V.

This use case discusses the first scenario.

Scenario Details

- The branch users access local services (print, DHCP, Active Directory) that are virtualized.

- Two physical NIC interfaces are bridged together in the virtual EX-V.
- Users connections from the branch office to the Data Center applications are in-line through the Exinda virtual machine(s) on both ends of the connections, and through external NIC interfaces.
- The Exinda provides Visibility, Control, and Acceleration for all traffic in this configuration.

Note: In this configuration VMware supports vMotion, HA, and Fault Tolerant.

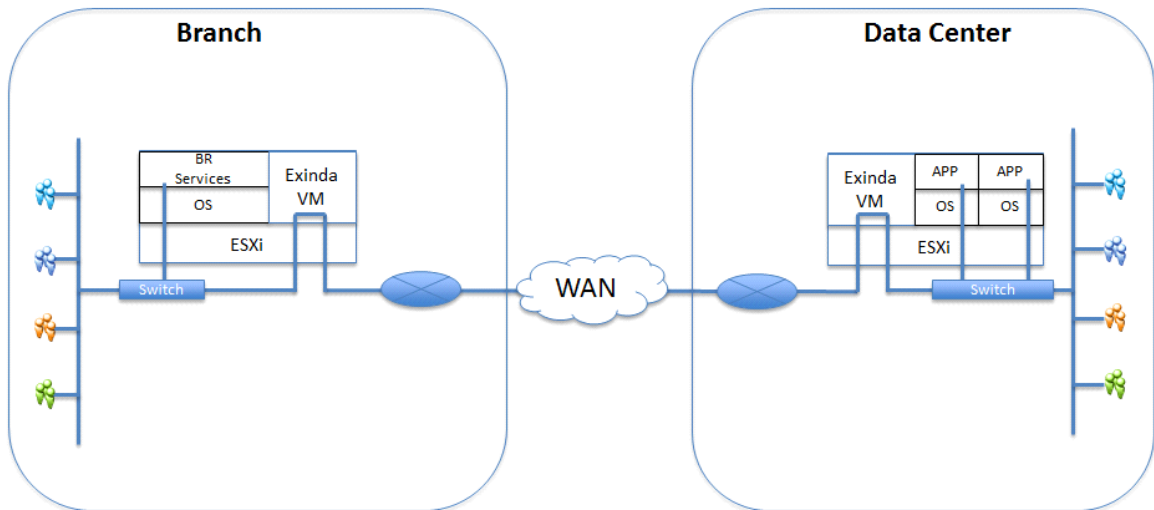

Optionally, install the EX-V in a separate ESXi host in an Inline-mode configuration and connect through an external switch.

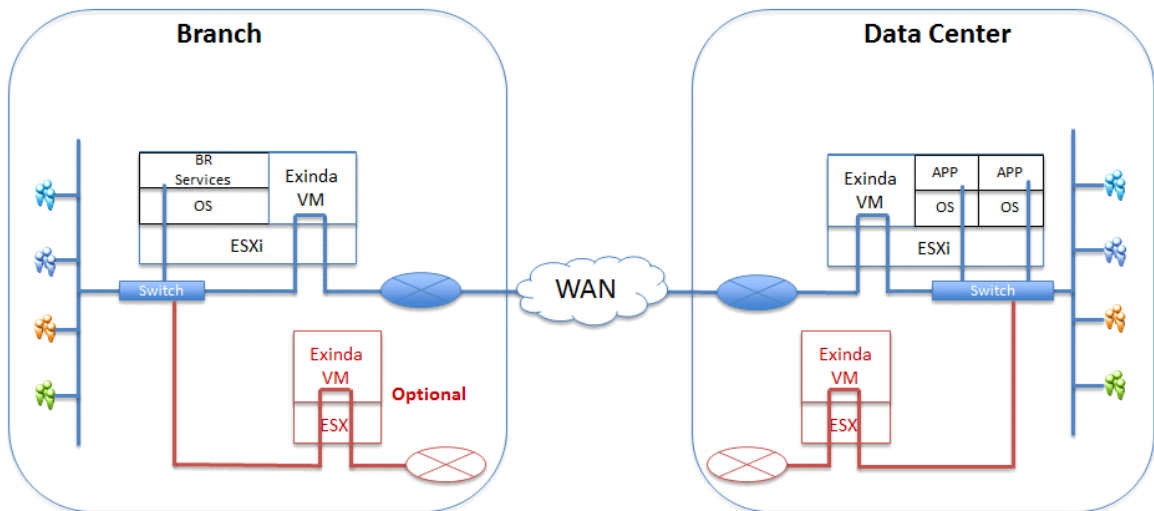

5.2.1 Use Case 1: Expanded View of VMware ESXi

This configuration will be in either a branch office with virtual infrastructure, or in the data center where the applications are running on the host VM and local users accessing the WAN leverage the Exinda for Visibility, Control, and Acceleration.

Scenario Details

- In the diagram below, a local LAN is sitting behind the host running VMware ESXi hypervisor.
- The physical server is a re-purposed Dell Server and has the following physical/logical interface mappings for illustration purposes only (you are encouraged to select your own server):

ESXi Ethernet Ports	NIC0	NIC1	NIC2	NIC3
Exinda Ethernet Ports	ETH0	ETH1	ETH2	ETH3
ESXi Virtual Switches	SW0	SW1	SW2	SW3

- The host has four NIC interfaces. NIC 0 is dedicated for management of the system and NIC 1 is idle or used for other purposes.
- NIC2 & NIC3 are mapped to SW2 and SW3.
- SW2 & SW3 are mapped to EX-V ETH2 & ETH3.
- ETH2 & ETH3 are mapped to NIC 2 and NIC 3, and are configured and bridged together by the Exinda virtual appliance. See In-line Mode Configuration in the [Exinda User Guide](#).
- VMware version = 4.1 & 5.0.
- The data path is from a client on the local LAN goes through the Exinda virtual appliance in In-line Mode and out to the WAN.
- Exinda EX-V software version = 6.3
- The diagram and deployment does not account for external storage. This deployment works with either local or external storage.
- vSphere Client and or vSphere Server are used to manage the system

Note: In this configuration VMware supports vMotion, HA, and Fault Tolerant.

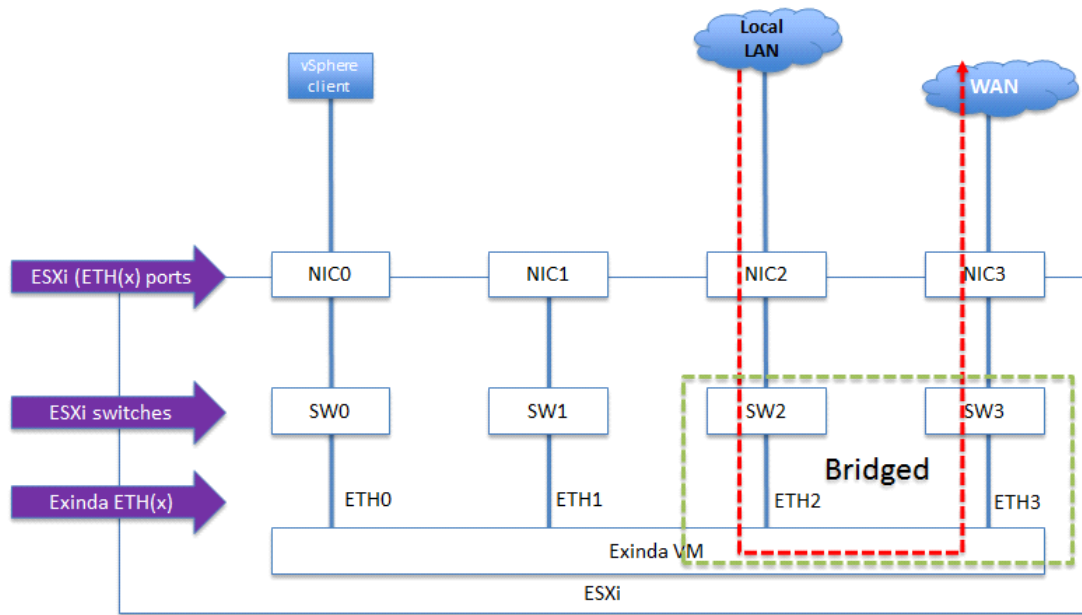

5.3 Use Case 2: In-line deployment with an isolated virtual LAN and virtual applications

In this use case the EX-V is set up for In-Line mode deployment with an isolated virtual LAN and virtual applications. There are primarily two scenarios for in-line deployment of the virtual appliance:

1. The LAN side users and applications connect to the EX-V via a physical NIC interface.
2. The applications are virtualized and isolated on the same host as the Exinda on the LAN side interface of the EX-V.

This use case discusses the second scenario.

Scenario Details

- Branch users access virtualized local services (print, DHCP, Active Directory).
- One physical NIC interface is configured to the WAN side link.
- Two virtual switches, one with virtual applications attached, and a second switch are bridged together in the virtual EX-V. The first switch is on the LAN side; the second one is for the WAN side. This results in isolating the applications behind the EX-V.
- Users connecting from the branch office to the Data Center applications are in-line through the Exinda virtual machine(s) on both ends of the connections and through a single external NIC interface to the WAN.

- The Exinda provides Visibility, Control, and Acceleration for all traffic in this configuration.

Note: In this configuration VMware does not support vMotion and Fault Tolerant. HA is supported.

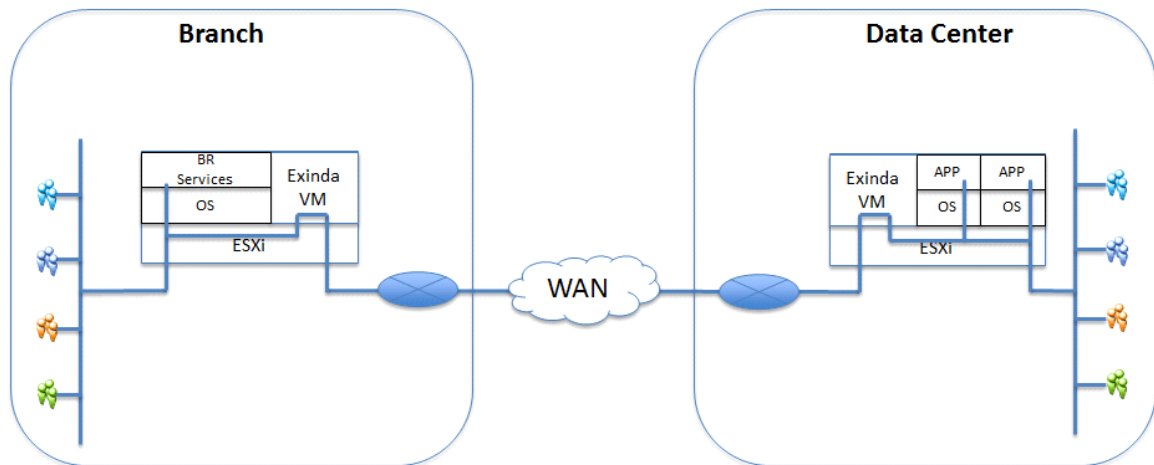

5.3.1 Use Case 2: Expanded View of VMware ESXi

This configuration will be in either a branch office with virtual infrastructure, or in the data center where the applications are running on the host VM and local users accessing the WAN leverage the Exinda for Visibility, Control, and Acceleration.

Scenario Details

- In the diagram below, a virtual LAN is isolated and sits behind the EX-V all running on the same host running VMware ESXi hypervisor.
- The physical server is a re-purposed Dell Server and has the following physical/logical interface mappings for illustration purposes only (you are encouraged to select your own server):

ESXi Ethernet Ports	NIC0		NIC3
Exinda Ethernet Ports	ETH0	ETH2	ETH3
ESXi Virtual Switches	SW0	SW2	SW3

- The host has two NICs; NIC 0 is dedicated for management of the system and NIC 1 is idle or used for other purposes.
- All virtual application workloads are configured in the ESXi to SW2.

- SW2 is configured to map to EX-V ETH2
- ETH2 is configured as part of a bridged connection defined as BR2.
- BR2 bridges NIC 2 and NIC 3 together in the Exinda virtual appliance. See In-line Mode Configuration in the [Exinda User Guide](#).
- The data path for any application connected to the SW2 virtual switch goes through the EX-V in in-line mode through the ETH2/ETH3 bridged configuration and out the NIC3 interface to the WAN.
- OPTIONAL: If this is a branch office with local users, configure local users to connect through the NIC2 ESXi interface and SW2/ETH2 EX-V interface and out to the WAN. This requires mapping a third NIC interface.
- VMware version = 4.1 & 5.0
- Exinda EX-V software version = 6.3

Note: In this configuration VMware does not support vMotion and Fault Tolerant. HA is supported.

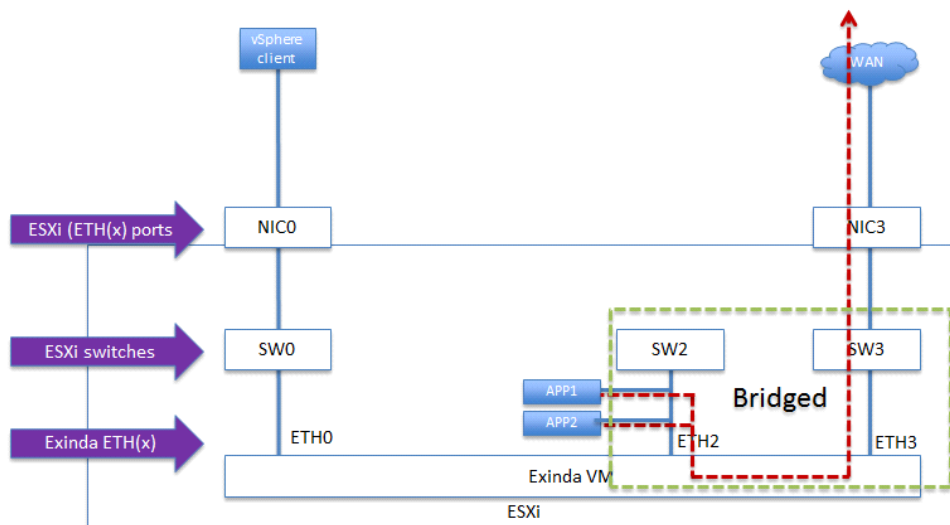

5.4 Use Case 3: Out-of band (WCCP) mode

In this use case the EX-V is set up for out of band mode, using WCCP protocol for deployment. There are other similar deployment methods for out of band, such as PBR or policy based routing that are not supported with the 6.3 software release. This deployment is typical for customers who have chosen to redirect a percentage of their traffic for acceleration and traffic shaping through the Exinda virtual appliance. In the event of a failure of the EX-V all traffic previously redirected to the EX-V will go through un-optimized and un-accelerated.

To configure for WCCP on the Exinda-V, see the [Exinda How to Guide: WCCP](#).

Scenario Details

- Branch users access local services (print, DHCP, Active Directory) that are virtualized.
- One physical NIC interface is dedicated for management of the virtual machines and hypervisor.
- One physical NIC interface is configured on the hypervisor for LAN access, and has a routed connection to the WAN router.
- One physical NIC interface is configured and mapped to the AUX port on the EX-V.
- **OPTIONAL:** It is possible to configure and map all data traffic through a single NIC interface on the hypervisor; however, for performance reasons it is recommended to segment the un-optimized traffic from the optimized traffic.
- User access from the branch office to the Data Center applications has two paths:
 - Path one is directly to the WAN router, with no traffic shaping or acceleration.
 - Path two is through the re-directed path invoked by the router (using WCCP) to the Exinda virtual appliance. The traffic is optimized and accelerated.
- Traffic on the Data Center side has the same path as the branch side. Traffic that is selected to be optimized and accelerated is redirected to the EX-V through WCCP on the WAN router.
- The Exinda provides Visibility, Control, and Acceleration for only redirected traffic in this configuration

Note: In this configuration VMware supports vMotion, HA, and Fault Tolerant.

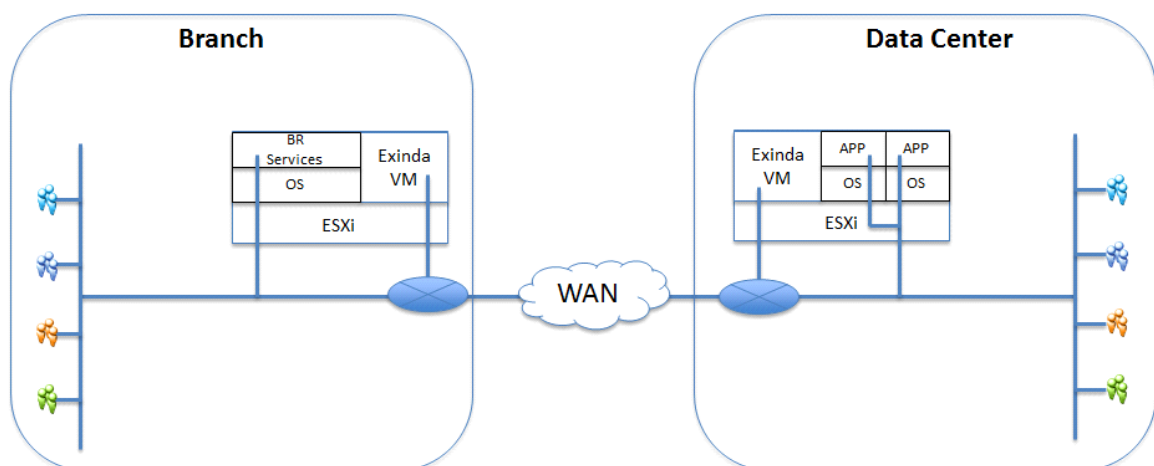

5.4.1 Use Case 3: Expanded View of VMware ESXi

This configuration will be in either a branch office with virtual infrastructure, or in the data center where the application and local user traffic accessing the WAN is redirected to the Exinda virtual appliance for Visibility, Control, and Acceleration.

Scenario Details

- In the diagram below, a virtual LAN with application servers (APP1 W2003 or 8 and APP2) are configured in the ESXi hypervisor on SW1 and mapped to NIC1. They have a direct path the WAN router.
- The physical server is a re-purposed Dell Server and has the following physical/logical interface mappings for illustration purposes only (you are encouraged to select your own server):

ESXi Ethernet Ports	NIC0	NIC1	NIC2
Exinda Ethernet Ports	ETH0	ETH1	ETH2
ESXi Virtual Switches	SW0	SW1	SW2

- The host has three NICs; NIC 0 is dedicated for management of the system
- NIC 1 is dedicated to all virtual application workloads hosted on the ESXi.
- All virtual application workloads are configured in the ESXi to SW1.
- The EX-V is configured on SW2 virtual switch and is mapped to the NIC2 interface.
- The NIC2 interface has a direct connection to the WAN router, and is configured for WCCP GRE layer 3 mode between the router and the EX-V. See the [Exinda How to Guide: WCCP](#).
- VMware version = 4.1 & 5.0
- Exinda EX-V software version = 6.3
- The data path for virtualized applications configured on SW1 takes two paths:
 - Path one – un-optimized and un-accelerated traffic is forwarded directly to the WAN router through NIC1.
 - Path two – traffic to be optimized (traffic shaped) and accelerated traffic is forwarded to the router for redirection through WCCP to the EX-V through NIC2/SW2 on the AUX port of the EX-V.

- **OPTIONAL:** It is possible to configure and map all data traffic on SW1 and SW2 to the NIC1 interface; however, for performance reasons it is recommended to segment the optimized traffic on its own NIC and virtual switch for performance reasons, and in the event of failure of the EX-V virtual appliance.

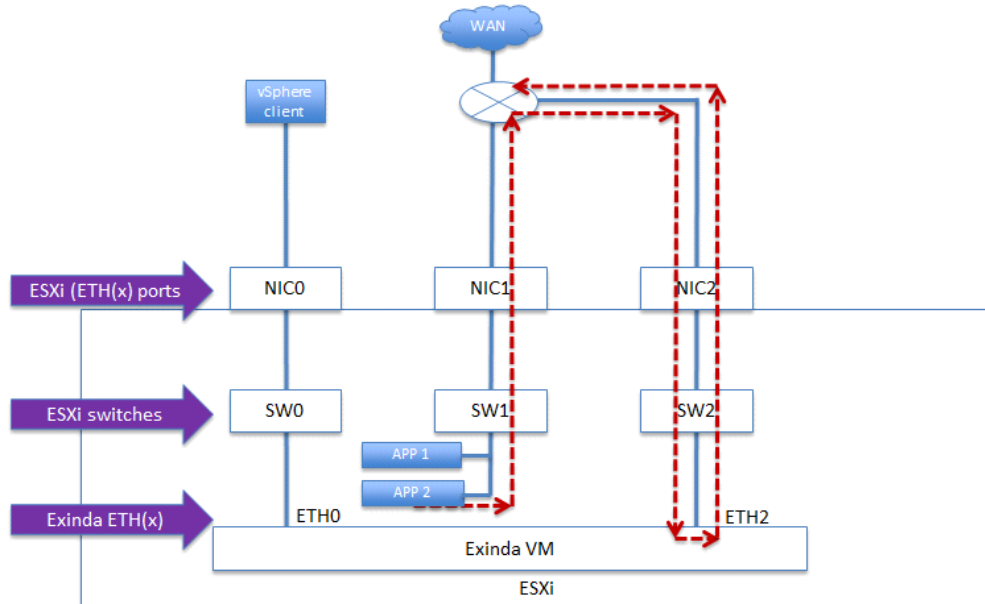

5.5 Use Case 4: Port Mirroring / SPAN Port Configuration

In this use case the EX-V is set up to monitor and collect traffic for reporting. This topology is used when customers need to monitor only, without installing the Exinda in in-line mode. The Exinda will monitor and report on all applications presented on the SPAN/mirror port. This is regularly used to perform network audits as it provides great flexibility in restricted and complex network environments.

To configure SPAN and Port Mirroring on the EX-V, see the [Exinda How to Guide: SPAN and Port Mirroring](#) guide.

There are two deployment scenarios to consider:

- Port mirroring on a switch that is external to the hypervisor host.
- Port mirroring on a virtual switch that is the primary switching fabric in the virtual hypervisor.

5.5.1 Use Case 4: Expanded View of VMware ESXi with external Nexus switch

Scenario Details

- The customer has selected Exinda for its monitoring and reporting service. The EX-V is configured as virtual machine on an ESXi hypervisor, on a dedicated NIC2 interface, and dedicated virtual switch SW2.
- The EX-V management port is mapped to SW0 and NIC0.
- The ESXi host EX-V has three four Ethernet interfaces (0-23) with the APP1-3 mapped to SW1 and NIC1 respectively, and connected to the external Nexus Switch.
- The EX-V with the AUX (ETH1) port is configured for SPAN Port Mirroring and management of the EX-V.
- The NIC2 interface is connected to an external switch on a port that has been configured to support SPAN port mirroring. It is recommended that this port be dedicated so there is no impact to traffic performance.
- Application virtual workloads (APP1 to 3) are on a separate virtual SW1 and mapped to NIC1.
- NIC1 is directly attached to the external Nexus switch.

Note: In this configuration VMware supports vMotion, HA, and Fault Tolerant.

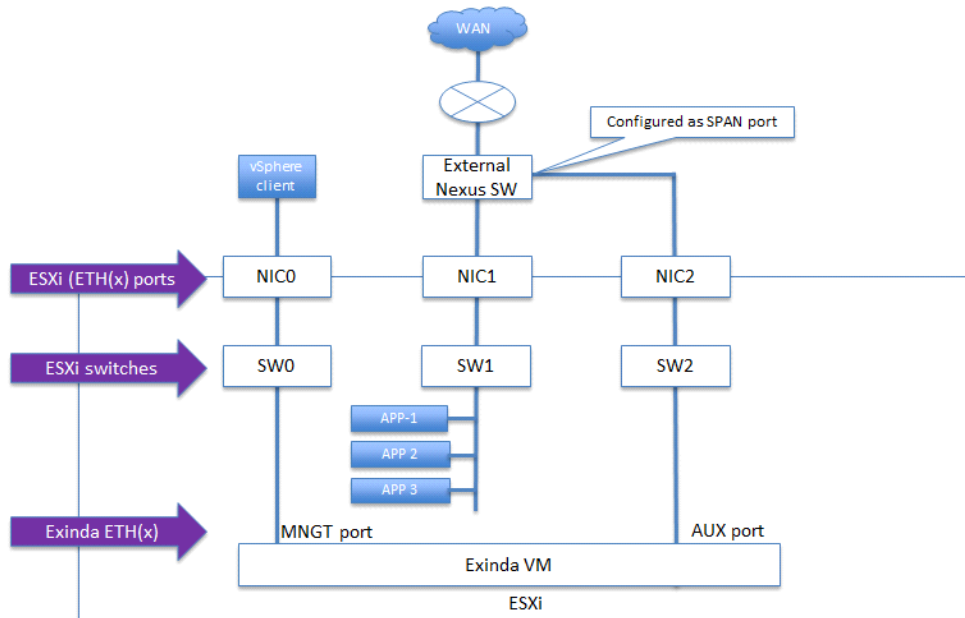

5.5.2 Use Case 4: Expanded View of VMware ESXi with a virtual Nexus switch

Scenario Details

- The Cisco Nexus 1000V Series VEM runs as part of the VMware ESX or ESXi kernel and replaces the VMware Virtual Switch functionality. The VEM uses the VMware vNetwork Distributed Switch (vDS) API, which was developed jointly by Cisco and VMware, to provide advanced networking capability to virtual machines. This level of integration helps ensure that the Cisco Nexus 1000V Series is fully aware of all server virtualization events, such as VMware vMotion and Distributed Resource Scheduler (DRS). The VEM takes configuration information from the VSM and performs Layer 2 switching and advanced networking functions namely Monitoring:
 - NetFlow
 - Switch Port Analyzer (SPAN)
 - Encapsulated Remote SPAN (ERSPAN)
- VMware versions - 4.1 and 5.0
- EX-V versions – 6.3
- The Nexus 1000V is configured and mapped to NIC1, which has a direct connection to the WAN router.
- The EX-V has two four Ethernet interfaces (ETH0 / ETH10-3) with the AUX (ETH1) configured for Mirroring and ETH0 for management and management of the EX-V.
- The EX-V AUX port is configured to a port configured with SPAN port mirroring on the Nexus 1000V. This port should be dedicated to ensure there is no performance impact to data traffic.
- The applications (APP1 to 3) are connected to a separate switch port on the Nexus 1000V.

Note: In this configuration VMware supports vMotion, HA, and Fault Tolerant.

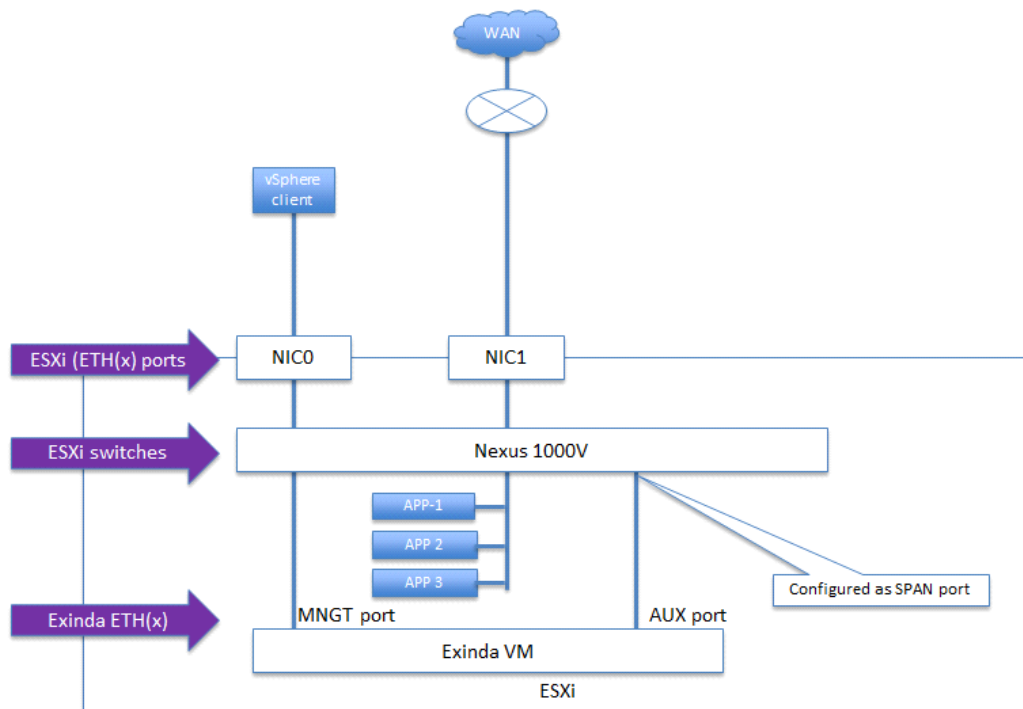

5.6 Use Case 5: Virtual WAN Simulator in Isolated Network

The purpose of this deployment is for partners, customers, and Exinda Sales Engineers to have an isolated environment for demonstrations and functional testing of EX-V. The benefit is the portability and lack of impact to a production network. This virtual deployment can be installed on a laptop that has processor support for VT (virtual technologies) enablement and 64 Bit.

Scenario Details

- A single host that is running a hypervisor with the following components:
 - At least one Windows client (Windows XP or 7)
 - Two EX-V virtual appliances
 - One virtual WAN simulator
 - One Windows server (2003 or 2008)
 - Web Server and or FTP services configured on the Windows Server
- This deployment can be run either in VMware or XenServer.

5.6.1 Use Case 5: Expanded View of VMware ESXi & WAN simulator

- The hypervisor has one NIC:
 - NIC0, NIC2, and NIC3 are unused
 - NIC1 is connected to an external network and has access to the WAN for management and licensing of the virtual machines.

NOTE: Any physical NIC interface can be used, NIC1 is used for illustration purposes.

- VMware software version = 4.1 & 5.0
- Exinda EX-V software version = 6.3
- WANEM Virtual Simulator software = 2.3
 - <http://wanem.sourceforge.net/>
 - You can use your own WAN simulator of choice
- Four virtual switches have been defined on the ESX/ESXi host:
 - BR_LAN – branch side LAN switch
 - BR_WAN – branch side WAN switch
 - DC_WAN – data center side WAN switch
 - DC_LAN – data center side LAN switch
- Each EX-V is configured for INLINE Mode and a single management interface on ETH0.
- DHCP is assumed on the network for management interfaces on the EX-V appliances.
- Private network space is configured for the Windows Client and Server on the data path between them and a second Ethernet interface is configured for DHCP to manage each system through RDP.
- EX-V and the WAN Simulator data path are bridged.
- Optionally, you can configure the WAN Simulator as a router and change the default gateway of the client and server accordingly.

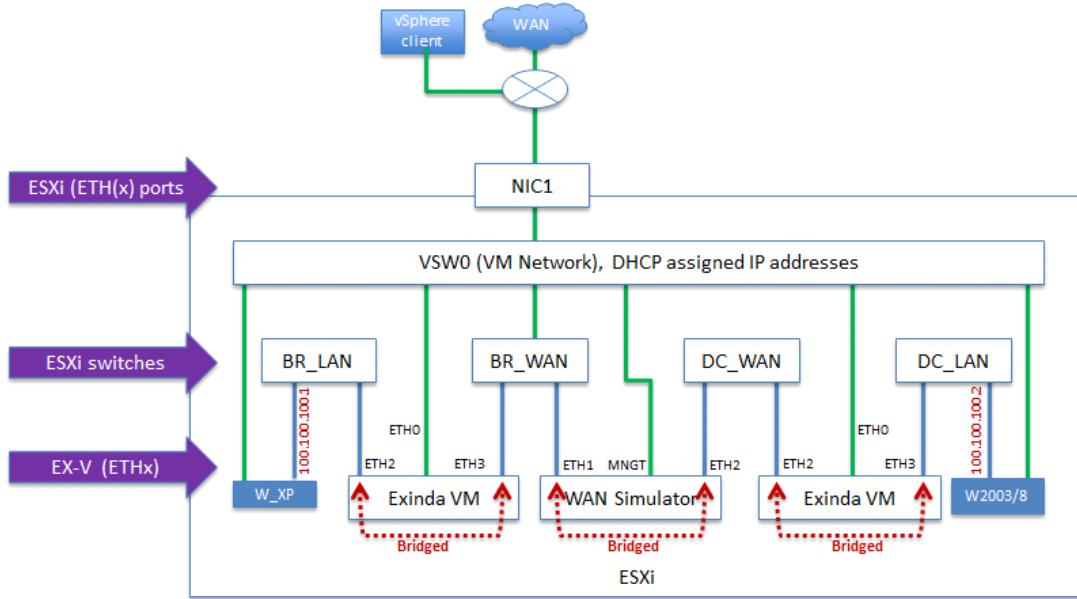

- Optionally you can with with a system that has at least 3 NIC interfaces you can attach an external workstation and server and pass traffic through the demo system.
 - You will need to configure on the ESX/ESXi host mapping BR_LAN to NIC0 and DC_LAN to NIC3 to connect the external workstation and server.
 - The benefit is you can test through the isolated virtual EX-V environment with no impact to a product network

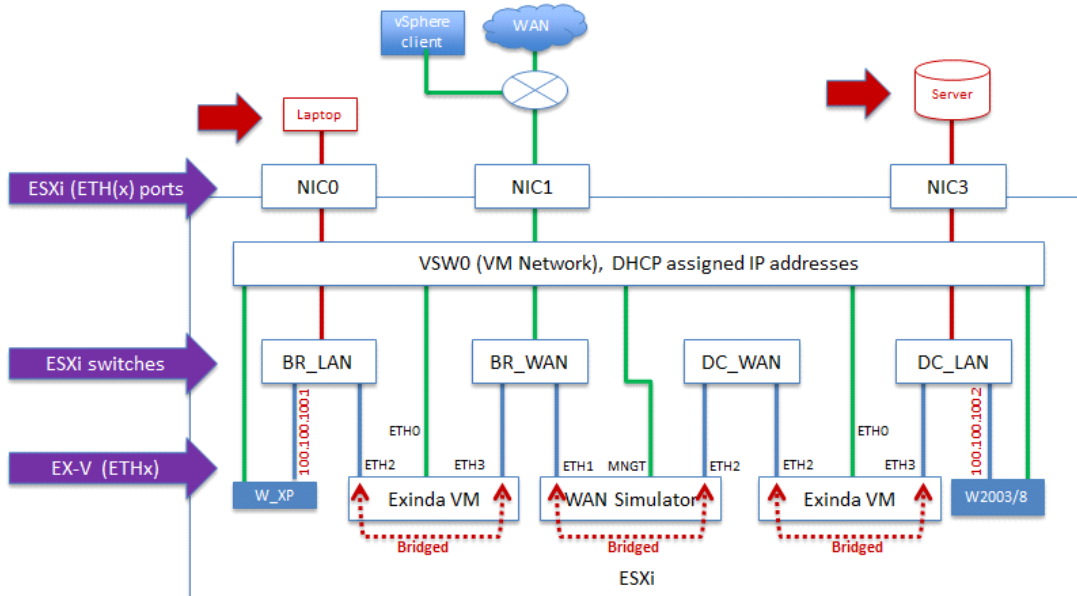

5.7 Use Case 6: VMware High Availability

In this use case we discuss the recommended configuration and best practices for installing the Exinda virtual appliance where the requirement is for:

- Exinda Active / Active (software version – 6.3),
- ESX/ESXi HA (software versions 4.0, 4.1 and 5.0),
- vMotion support,
- vMotion = Yes for INLINE-line
- VMware best practice recommends that at least three hosts are used for this configuration, and
- Licensing for the EX-V units will include two full licenses and one cold standby license. Each EX-V must maintain network connectivity with the Exinda License server and will shut down the Exinda virtual appliance after 96 hours without a successful connection.

Scenario Details

- There are six ESX/ESXi hosts (can be done with three):
 - Two running virtual workloads, and a third as the backup HA system
 - Two running EX-V appliances and a third running as a cold standby
- Optionally you can move the EX-V to co-reside on the same hosts as the virtual workloads; however if vMotion is a requirement you must provide an external switch and separate NIC to pass the traffic between the workloads and the EX-V.
- Having a separate host for the EX-V allows you to:
 - Segment other virtual appliances from the application workloads.
 - Support vMotion just for the application workloads and not for the host running the Exinda virtual appliance.
- There are two networks:
 - A management network for vMotion and access to the external workload VMDK data stores.
 - A production network for data traffic to and from the applications and WAN.
- This configuration assumes INLINE mode; optionally you can run in out of path mode, but WCCP is required.

- Downtime for any workload in HA mode is for the duration of the virtual workload and/or the EX-V to reboot.

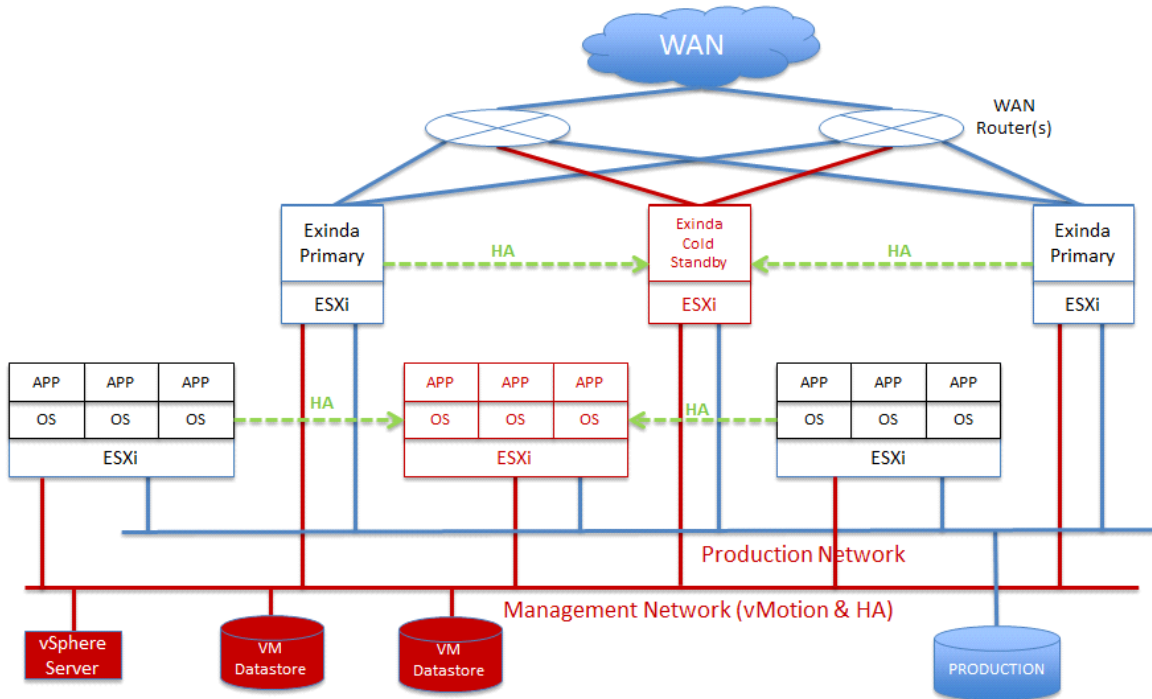

5.8 Use Case 7: VMware Fault Tolerant Cluster

In this use case we discuss the recommended configuration and best practices for installation of Exinda virtual appliance where the requirement is for:

- Exinda Active / Passive (cold standby) - (software version – 6.3),
- ESX/ESXi Fault Tolerant Cluster (software versions 4.0, 4.1, and 5.0),
- vMotion support,
- vMotion = Yes for INLINE,
- VMware best practice recommends that at least 4 hosts are used for this configuration, and
- Licensing for the EX-V units will include one full license and one cold standby license.
 - Each EX-V must maintain network connectivity with the Exinda License server and will shut down the Exinda virtual appliance after 96 hours without a successful connection.
- Optionally, the EX-V can co-reside with the Application workloads, but an external switch and an additional NIC is required for vMotion support.

Scenario Details

- There are four ESX/ESXi Hosts:
 - one running virtual workloads and a second as the Fault Tolerant system
 - one running EX-V active and a second running as a cold standby and Fault Tolerant.
- Optionally, move the EX-V to co-reside on the same hosts as the virtual workloads; however if vMotion is a requirement you must provide an external switch and separate NIC to pass the traffic between the workloads and the EX-V.
- Having a separate host for the EX-V allows you to:
 - Segment other virtual appliances from the application workloads.
 - Support vMotion just for the application workloads, and not for the host running the Exinda virtual appliance.
- There are two networks:
 - A management network for vMotion and access to the external workload VMDK data stores
 - A production network for data traffic to and from the applications and WAN
- This configuration assumes INLINE mode; optionally you can run in out of path mode which requires WCCP.
- This configuration has 100% uptime for one virtual workload per host for VMware version 4.1, and up to four virtual workloads in 5.0.

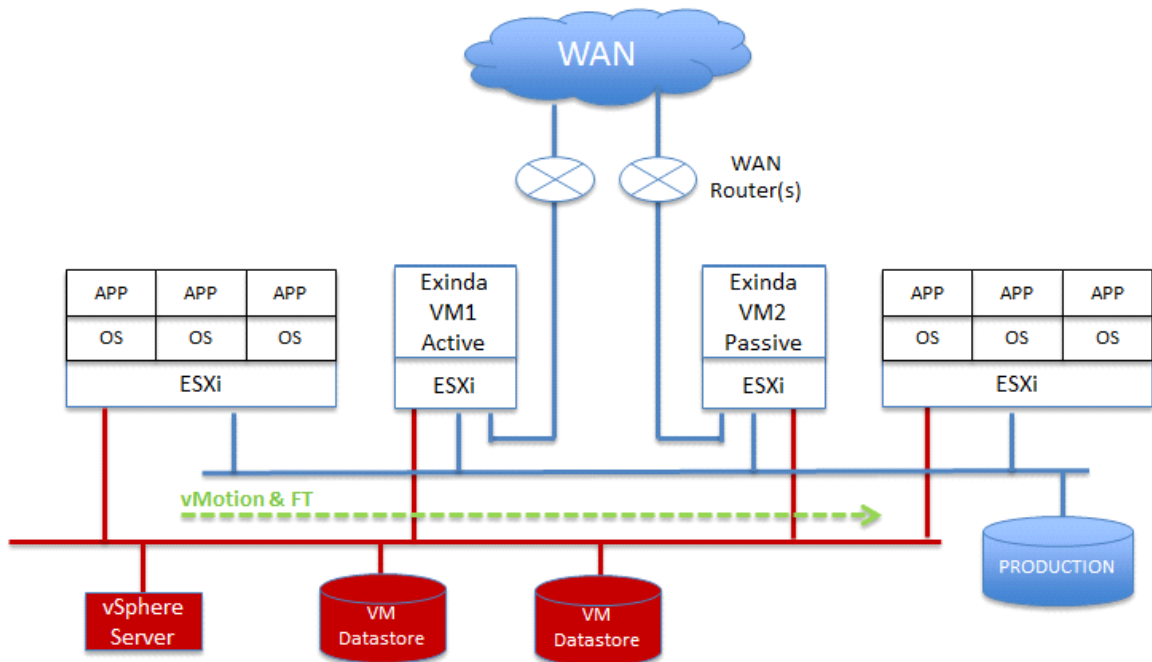

5.9 Hypervisor Limitations

Consider these additional planning items when installing EX-V on other Hypervisors in the market including:

- XenServer 5.0, 5.5, and 6.0
- Microsoft Hyper-V on Windows 2008 R2
- KVM

What are the known limitations?

- XenServer
 - No Silicom Hardware Bypass Card driver support. Exinda is working with our NIC vendor to provide this support.
 - Promiscuous mode is supported, and must be configured via the CLI. You can find the commands in the Exinda Virtualization How to Configure Guide, or refer to the Citrix site for XenServer hypervisor configuration guidance.
 - Traffic shaping, reporting, and optimization are supported for INLINE mode.
 - Reporting and optimization are supported for out of path (WCCP GRE) mode.
- VMware

- Bypass NIC card drivers are supported in 4.1 and 5.0.
- Hyper-V
 - No support for Parallel virtualization drivers, meaning the guest machine does not know it's virtualized.
 - Only out of band deployments are supported for Hyper-V.
- KVM
 - Images for KVM are not published on the Exinda support website, you will need to contact support for the KVM images
- External storage is supported and recommended for virtual machine workloads, and the Exinda virtual appliance
- In the diagram below, the Exinda is running in Active/Active mode with a Heartbeat between the two systems. There must be a separate Virtual NIC configured for Heartbeat traffic to transit

